

ORDINANCE NO. 20060209-Z001

AN ORDINANCE AMENDING SECTION 25-2-757, SECTION 25-2-760, AND CHAPTER 25-2, APPENDIX C OF THE CITY CODE RELATING TO BUILDING SETBACKS, STREETScape IMPROVEMENTS, AND BUILDING HEIGHTS IN THE UNIVERSITY NEIGHBORHOOD OVERLAY DISTRICT.

BE IT ORDAINED BY THE CITY COUNCIL OF THE CITY OF AUSTIN:

PART 1. Subsection 25-2-757(A) (*Setbacks*) of the City Code is amended to read:











- (A) There are no minimum front yard or street side yard setbacks, except for[~~;~~
(1) ~~the~~] minimum setbacks of [are] 10 feet along Martin Luther King, Jr. Blvd. between Rio Grande Street and San Gabriel Street.~~and;~~
(2) ~~the minimum front yard setback is two feet along Graham Place, West 24-1/2 Street, San Pedro Street, West 21st Street, and Hume Place.~~]

PART 2. Subsection 25-2-760(B) (*Streetscape Improvements*) of the City Code is amended to read:

- (B) A site owner shall install a sidewalk not less than five feet wide along West 24-1/2 Street, San Pedro Street, West 21st Street west of Pearl Street, Hume Place, or Salado Street.
- (C) The minimum width of sidewalks is 12 feet along West 21st Street from Guadalupe Street to Pearl Street.

PART 3. Chapter 25-2, Appendix C (*University Neighborhood Overlay District Boundaries, Subdistrict Boundaries, and Height Limits*) of the City Code is amended to delete the “University Neighborhood Overlay Height Limits” map and replace it with the following new map:

Heights

-  40 Foot Zone
-  45 Foot Zone
-  50 Foot Zone
-  60 Foot Zone
-  70 Foot Zone
-  75 Foot Zone
-  90 Foot Zone
-  120 Foot Zone
-  175 Foot Zone
-  220 Foot Zone

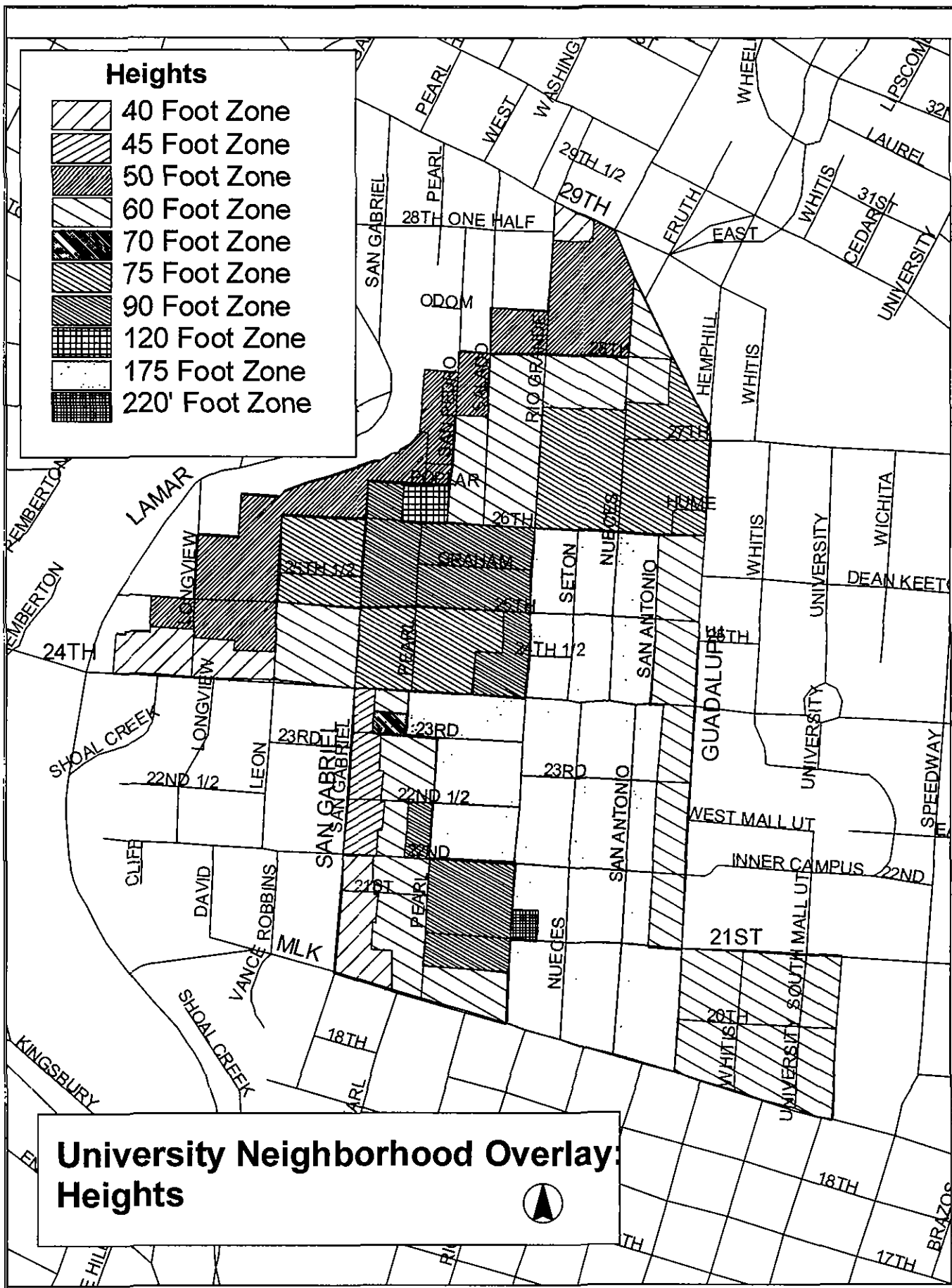

**University Neighborhood Overlay
Heights**



PART 4. This ordinance takes effect on February 20, 2006.

PASSED AND APPROVED

February 9, 2006

§
§
§



Will Wynn
Mayor

APPROVED:

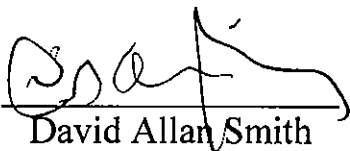

David Allan Smith
City Attorney

ATTEST:

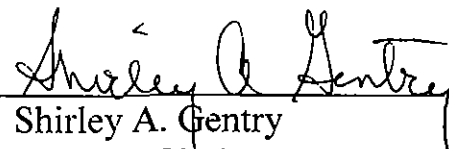

Shirley A. Gentry
City Clerk